

# Complete, Easy To Read INSTALLATION AND OPERATING INSTRUCTIONS

## LUXPRO® PSDH021Ba

### BATTERY POWERED, NON-PROGRAMMABLE DIGITAL HEAT PUMP THERMOSTAT

LUX PRODUCTS CORPORATION 52041  
Mt. Laurel, New Jersey 08054, USA

**WARNING:** Use Energizer® or DURACELL® Alkaline Batteries Only. Energizer® is a registered trademark of Eveready Battery Company, Inc. DURACELL® is a registered trademark of The Gillette Company, Inc.

#### IMPORTANT!

Please read all instructions carefully before beginning installation and save for future reference. Before removing any wiring from your existing thermostat, the wires must be labeled with their terminal designations. Ignore the color of the wires since they may not comply with any standard.

Thank you for your confidence in our product. You should become fully acquainted with this thermostat before installing it for usage. Follow the installation procedures carefully, and one step at a time. This will save you time and minimize the chance of damaging either the thermostat or the systems that it controls. These instructions may contain information beyond that required for your particular installation. Please save these instructions for future reference.

#### COMPATIBILITY

- The PSDH021Ba thermostat can be used with most 24 volt: single-stage heat pumps, and 2 heat / 1 cool heat pump systems.
- This thermostat cannot be used to control: conventional heating and cooling systems, 3-wire zone valves, or 120/240 volt (line voltage) heating or cooling systems. Ask your dealer for other LUXPRO® thermostats to control those systems.

#### FEATURES

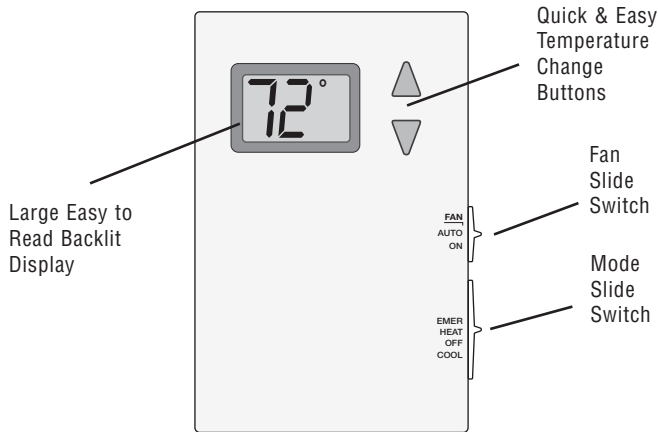

- Digital, Non-Programmable
- Battery Powered Only
- Set Temperature Range 45°F to 90°F
- Clean, Attractive Design
- Large, Easy To Read Display with LED Backlight
- Easy To Install
- F / C Selectable Temperature Display
- Fixed 5 Minute Minimum Run / Off Time For Compressor Protection
- Adjustable Temperature Stops

#### INSTALLATION

**PLEASE READ ALL INSTRUCTIONS CAREFULLY BEFORE BEGINNING INSTALLATION.**

#### CAUTION:

This thermostat is protected against normal static electric discharges. However, in extremely dry weather you should touch a grounded metal object before touching the thermostat to minimize the risk of causing damage to the unit.

#### TOOLS REQUIRED:

- #1 Phillips screwdriver (small - medium)
- Drill with 3/16-in. (4.8mm) drill bit
- Wire stripper/cutter

#### CAUTION:

Turn off electricity to the appliance before installing or servicing the thermostat or any part of the system. Do not turn the electricity back on until the work is completed.

- Your thermostat is a precision instrument. Please handle it with care.
- Do not short (jumper) across the electric terminals on your heating or cooling equipment to test the system. This may damage the thermostat and void your warranty.
- All wiring must conform to all applicable local codes and ordinances.
- This thermostat is limited to a maximum of 1.5 amps, total current; higher current may cause damage to the thermostat.

#### THERMOSTAT LOCATION:

On replacement installations, mount the new thermostat in place of the old one unless the conditions listed below suggest otherwise. On new installations, follow the guidelines listed below.

- Locate the thermostat on an inside wall, at about 5 ft. (1.5m) above the floor, and in a room that is used often.
- Do not install it where there are unusual heating conditions, such as: direct sunlight, near a lamp, television, radiator, register, fireplace, on a wall opposite a stove, or that carries hot water pipes.
- Do not locate in unusual cooling conditions, such as: on a wall separating an unheated room, or in a draft from a stairwell, door, or window.
- Do not locate where air circulation is poor, such as: in a corner or alcove, or behind an open door.
- Do not locate in a damp area. This can lead to corrosion that may shorten thermostat life.
- Do not install the unit until all construction work and painting has been completed.

#### REMOVING THE OLD THERMOSTAT:

- Switch OFF the electricity to the heating/cooling equipment; then proceed with the following:
- Remove the front cover from your old thermostat. Most will simply pull straight off, while others may be fastened by screws.
- Take note of the letters printed near each of the wire terminals. Attach adhesive labels (enclosed) to each wire for identification by their **terminal letter**, not the color of the wire.
- Make sure the wires do not fall back inside the wall. Remove and label each wire one at a time, and do not allow the wires to touch each other or any parts of the thermostat.
- Loosen all screws on the old thermostat base, and remove it from the wall.

#### MOUNTING THE NEW THERMOSTAT:

- Strip insulation leaving approximately 3/8 in. (10mm) of bare wire on the ends, and clean off any corrosion present.
- Fill the wall opening with non-combustible insulation to prevent drafts from affecting the thermostat while in use.
- Pull your new thermostat apart by applying pressure to the thumb tab on the bottom edge of the unit, while pulling the front and back halves apart from the bottom edge of the thermostat.

**NOTE:** If you are mounting the base to a soft material like plasterboard, or if you are using the old mounting holes, the screws may not hold. Drill a 3/16-in (4.8mm) hole at each screw location, and insert the plastic anchors provided.

- Route the wires through the large hole adjacent to the terminal block, and hold the base plate against the wall. Position the base for best appearance, and to hide any marks from an old thermostat. Attach the base to the wall with the two screws provided.

#### WIRING INFORMATION

**\*\* Complete heating or cooling system wiring can be found in the WIRE IDENTIFICATION AND WIRING SCHEMATICS section of this instruction sheet. The schematics show system components for brand new installations or for un-referenced wires.**

#### CONNECTING THE WIRES:

- Clean bare wire ends must be inserted in between the black clamp and the brass terminal as shown here.
- Securely tighten all electrical terminal screws (even unused ones).



#### SETUP OPTIONS

If batteries are presently installed, remove them from the thermostat before proceeding with changing any of the options listed below. A table similar to this one shown here is printed on the thermostat's circuit board.

|             | UP | DOWN |
|-------------|----|------|
| JP1 (SCALE) | F  | C    |
| JP2 (B / O) | B  | O    |

#### JUMPER SETTINGS:

There are 2 option jumpers located inside the thermostat on the circuit board. These settings can be changed from their default values by removing its corresponding black shorting cap and installing the cap so that it is positioned on the adjacent pair of metal pins. A change to either of the option jumpers will not be recognized unless the thermostat has been without battery power for at least 2 minutes, and then power is restored again. Each of these jumpers changes a different setup option. The choices for these options are listed in a table printed on the circuit board, and are also printed adjacent to each individual setting jumper.

#### JP1 - FAHRENHEIT OR CELSIUS DISPLAY FORMAT:

This setting controls whether the temperature is shown in degrees °F or °C on the LCD display screen.



#### JP2 - [B] OR [O] TERMINAL USAGE OPTION:

This setting determines how the thermostat will use the shared B/O terminal connection on the back plate. Select the "B" option to have the B/O terminal powered while in heat mode, and un-powered while in cool and off modes. Select the "O" position to have the B/O terminal powered while in cool mode, and un-powered while in heat and off modes. If you are not sure which way to set this option, consult the manufacturer of your heat pump unit.



Once all optional jumper settings have been performed as described in the previous section, ensure that the thermostat has been without battery power for **at least 2 minutes** for the change to be recognized. Now install new batteries into the thermostat. When installing batteries, use two new Energizer® or DURACELL® "AA" size alkaline batteries only. Ensure that the batteries are installed in the proper direction as per the markings shown in the battery tray.

#### COMPLETING THE INSTALLATION

Install your new thermostat onto its base. To do this, start with the bottom tilted out towards you at first, and line up the two holes in the top of the thermostat with the two hooks on the top of the back plate. Slowly pivot the bottom of the thermostat towards the back plate and push firmly on the bottom half of the thermostat until it is securely latched to the back plate. If the two thermostat halves do not mate together easily, remove and try again. Do not attempt to force them together if they do not appear aligned properly.

**NOTE:** Before use, remove the plastic film (if present) that is protecting the LCD display screen.

Turn the electrical power back ON to both your heating and/or cooling systems. Verify that both systems are operating properly. When set to a high temperature, the heating system should provide warm air after a short time in Heat Mode. Likewise, the cooling system should provide cool air after a short time when set to a low temperature in Cool Mode. Usually, sound from the heater and/or cooling system units can be heard while either is running. Your installation is now complete.

#### FRONT PANEL ITEMS

#### SYSTEM MODE SWITCH:

The MODE switch has 4 positions: EMER, HEAT, OFF, and COOL. In the summer, set the switch to COOL to control cooling. In the winter, set the mode switch to HEAT to control heating; set the mode switch to EMER to control auxiliary heating only (if equipped). In the EMER position, the heat pump compressor is disabled. When set to OFF mode, the heating and cooling system will remain off.

#### FAN MODE SWITCH:

The FAN switch has 2 positions: AUTO and ON. In the AUTO position, the operation of the blower fan is determined only by the on/off cycling of the heating and cooling system. In the ON position, the system's blower fan will be commanded ON continuously at all times, even when the system mode switch is in the OFF position.

#### PUSH BUTTONS:

There are two push buttons to the right of the unit's display screen. These are used to adjust the set point temperature.

#### OPERATING INSTRUCTIONS

#### TEMPERATURE ADJUSTMENT:

While in HEAT, COOL, or EMER modes, a single press on either the UP or DOWN button causes the word "SET" to appear on the screen, and the set temperature value on the screen to start flashing. When flashing, the set temperature can be altered by pressing either the UP or DOWN button once per degree of change, or by holding either button for at least two seconds to automatically increment the set temperature quickly in the associated direction.

Based upon the relationship of the set temperature to the displayed ambient room temperature, the thermostat will engage the first stage of either heating or cooling, if a temperature demand is present.

If there is a large thermal demand present which is greater than the first stage of heating can accommodate, then a second stage of heating (W2) will be activated, showing the word "AUX" on the display screen. There is approximately a 4-minute delay that is imposed between the activation of the first stage of heating, and the second stage of heating.

#### DISPLAY ILLUMINATION:

Pressing either set temperature button will illuminate the display. The light will remain on for approximately 12 seconds. While the light is illuminated, pressing any of the 2 push buttons will cause the light to remain on for approximately 12 more seconds.

#### MINIMUM RUN/OFF TIME:

This is determined by the thermostat, and controls the minimum length of time that the thermostat must remain with Heat or Cool either On or Off, before it will automatically switch to the alternate On or Off state. This feature prevents rapid or short cycling, and also provides compressor protection. The duration of this delay is fixed at 5 minutes between on or off load changes.

#### BATTERIES AND MAINTENANCE

The batteries in the thermostat should be replaced AT LEAST once per year, or sooner if the "LO BAT" battery symbol appears in the lower right portion of the display screen.

To replace the batteries in the thermostat, remove the thermostat's body from the wiring base plate attached to the wall by pressing the thumb latch at the bottom center of the unit and swinging the front body out towards you, up and away from the base. Remove the used batteries from the battery tray and discard appropriately.

Install two new Energizer® or DURACELL®, "AA" size Alkaline batteries into the battery tray. Observe the polarity markings shown in the battery compartment to ensure proper installation. When finished, hang the top of the unit by the tabs at the top corners of the base, and then snap the bottom of the unit into place. Do not use unnecessary force. If the body does not snap into place easily, remove the body, re-hang it from the tabs at the top and try again.

#### TECHNICAL ASSISTANCE

If you have any problems installing or using this thermostat, please carefully and thoroughly review the instruction manual. If you require assistance, please contact our Technical Assistance Department at 856-234-8803 during regular business hours between 8:00AM and 4:30PM Eastern Standard Time, Monday through Friday. You can also receive technical assistance online anytime day or night at <http://www.luxproproducts.com>. Our web site offers you answers to the most common technical questions, and also permits you to email your questions to our technical support staff at your convenience.

#### WARRANTY

**Limited Warranty:** If this unit fails because of defects in materials or workmanship within three years of the date of original purchase, LUX will, at its option, repair or replace it. This warranty does not cover damage by accident, misuse, or failure to follow installation instructions. Implied warranties are limited in duration to three years from the date of original purchase. Some states do not allow limitations on how long an implied warranty lasts, so the above limitation may not apply to you. Please return malfunctioning or defective units to the location from which the purchase was made, along with proof of purchase. Please refer to "Technical ASSISTANCE" before returning thermostat. Purchaser assumes all risks and liability for incidental and consequential damage resulting from installation and use of this unit. Some states do not allow the exclusion of incidental or consequential damages, so the above exclusion may not apply to you. This warranty gives you specific legal rights and you may also have other rights which vary from state to state. Applicable in the U.S.A. and Canada only.

**HEAT PUMP TERMINAL CROSS REFERENCE CHART**  
**TABLAU DE RÉFÉRENCE CROISÉE DE BORNE DE POMPE À CHALEUR**  
**TABLA DE REFERENCIA PARA LA TERMINAL DE LA BOMBA DE CALEFACCIÓN**

| HEAT PUMP BRAND<br>MARQUE DE POMPES<br>À CHALEUR<br>MARCA DE LA BOMBA<br>DE CALEFACCIÓN | CORRESPONDING TERMINALS<br>BORNES<br>CORRESPONDANTES<br>TERMINALES<br>CORRESPONDIENTES |   |       |      |    |    |    |       |   |    | TAPE OFF (NOT USED)<br>RUBAN RETIRÉ<br>(NON UTILISÉ)<br>DESPRENDIMIENTO<br>(NO UTILIZADO) |   |
|---|--|---|-------|------|----|----|----|-------|---|----|---|---|
|   | E  | G | Y     | R    | O  | W2 | B  | C     | L |    |   |   |
| ARCO / Friedrich  | X2   | G | Y     | RC   |    | W2 | B  | C     |   |    |   |   |
| ARCO / Snyder General   | E  | G | Y     | R    | O  | W1 |    | C     |   | X  |   |   |
| BARB  | E  | G | Y1    | R    |    | W2 | B  | X     |   |    |   |   |
| BARB, HP, WH, MHP, HPQ  | E  | G | Y     | R    |    | W2 | W1 | X     |   |    |   |   |
| BDP / BRYANT  | E  | G | Y     | R    | O  | W1 |    | C     |   | F  |   |   |
| CARRIER   | E  | G | Y     | R    | O  | Y1 |    | C     |   | L  |   |   |
| CARRIER 5Q  | to W2  | G | Y, W1 | R    | O  | W2 |    | C     |   | L  |   |   |
| CARRIER 50Q, QT382  | E  | G | Y     | R    | O  | W2 |    | C     |   | L  |   |   |
| COLEMAN   |  | G | Y     | RED  | V  | W2 |    | BLACK |   |    |   |   |
| GE BAY  | X2   | G | Y     | R    | O  | W  |    | B     |   |    |   | T |
| HEIL-QUAKER / Whirlpool   |  | G | Y     | R    | O  | W  |    | B     |   |    |   |   |
| JANITROL / Goodman  | E  | G | Y     | R    | O  | W2 |    | C     |   |    |   |   |
| LENOX TYPICAL HP6   |  | F | M     | V/VR | R  | Y  |    | X     |   |    |   |   |
| LENOX HP8   | E  | F | M     | V/VR | R  | Y  |    | X     |   |    |   |   |
| LENOX HP9, 10   | E  | F | M     | V/VR | R  | Y  |    | X     |   | L  |   |   |
| LENOX HP16, 18, 19  | E  | F | M     | V/VR | R  | Y  |    | X     |   | L  |   |   |
| MAGIC CHEF PE   | E  | G | Y     | R    | O  | W  |    | C     |   |    |   |   |
| RHEEM / RUUD  | E  | G | Y     | R    |    | W2 | B  | X     |   |    |   |   |
| SNYDER GENERAL H-R811   |  | G | Y     | R    | O  | W1 |    | C     |   |    |   |   |
| TRANE   | X2   | G | Y     | R    | O  | W  |    | B     |   | F  |   | T |
| WEATHERKING   |  | G | W1    | R    | Y1 | E  |    | C     |   |    |   |   |
| WESCO   | E  | G | W1    | R    | Y1 | W2 |    | C     |   |    |   |   |
| WESCO / ADDISON   | E  | G | W1    | R    | O  |    |    | X     |   |    |   |   |
| WESTINGHOUSE H50  | E  | G | Y     | R    | O  | W  |    | X     |   | L1 |   |   |
| WESTINGHOUSE HE   |  | F | C     | V/VR |    | H2 | Z  | X     |   |    |   |   |
| WHITE RODGERS   | E  | G | Y     | R    | O  | W2 |    | C/X1  |   | L  |   |   |
| YORK  |  | G | Y     | R    | O  | W  |    | B     |   | X  |   |   |

**WIRING DIAGRAM NOTES:**

- The DASHED lines in wiring diagram #1 are optional depending upon your system type. Single stage heat pumps will not have wires present for the "E" or "W2" terminals. For a 2-Heat / 1-Cool system with NO Emergency heat wire, AUX heat will be connected to "W2". A jumper wire may be placed in between the "E" and "W2" terminals to allow Emergency Heat Mode.
- For Heat Pumps, use either the "B" or "O" wire, NOT BOTH.
- If "Y" and "C" wires are both present, then "C" is a common wire. Do not connect this "C" wire to your thermostat.
- If you have a "B" wire in your system that is used as a common wire, connecting it to the "B/O" terminal on this thermostat may damage your system and/or the thermostat.

**NOTES DU DIAGRAMME DE CÂBLAGE :**

- Les lignes en TRAITÉS TIRES du diagramme de câblage 1 sont optionnelles et leur utilisation dépend de votre type de système. Les pompes à chaleur à un étage n'ont pas de fils pour les bornes « E » ou « W2 ». Pour un système à 2 chauffage / 1 refroidissement SANS fil de chauffage d'urgence, la chaleur AUX sera branchée à « W2 ». Un fil de calter peut être placé entre les bornes « E » et « W2 » pour permettre l'utilisation du mode de chauffage d'urgence.
- Pour les pompes à chaleur, utilisez soit le fil « B » ou « O », NON PAS LES DEUX.
- Si vous avez les fils « Y » et « C », alors le « C » est le fil commun du système. Ne branchez pas ce fil « C » à votre thermostat.
- Si vous avez un fil « B » dans votre système et si ce fil est utilisé comme fil commun, le brancher à la borne « B/O » du thermostat pourrait endommager votre système et/ou le thermostat.

**NOTAS DEL DIAGRAMA DEL CABLEADO:**

- Las líneas PUNTEADAS en el diagrama del cableado #1 son opcionales, dependiendo del tipo de sistema. Las bombas de calefacción de una fase no contienen cables para las terminales "E" ni "W2". Para un sistema de 2 fases de calefacción y una de enfriamiento, NO se conecta el cable de calefacción de emergencia ni el auxiliar (AUX) en la terminal "W2". Puede colocarse un cable para formar un puente entre las terminales "E" y "W2" y permitir un modo de calefacción de emergencia.
- Para las bombas de calefacción, utilice el cable "B" o el cable "O", NUNCA USE AMBOS.
- Si tanto el cable "Y" como el "C" están presentes, entonces es más probable que el "C" sea el cable común del sistema. No conecte el cable "C" a su termostato.
- Si en su sistema hay un cable "B" que se utiliza como cable común, no lo conecte a la terminal "B" ni "O" del termostato, pues podría dañar tanto su aparato como su sistema.

**(PSDH021Ba) ENGLISH - WIRE IDENTIFICATION AND WIRING SCHEMATICS**

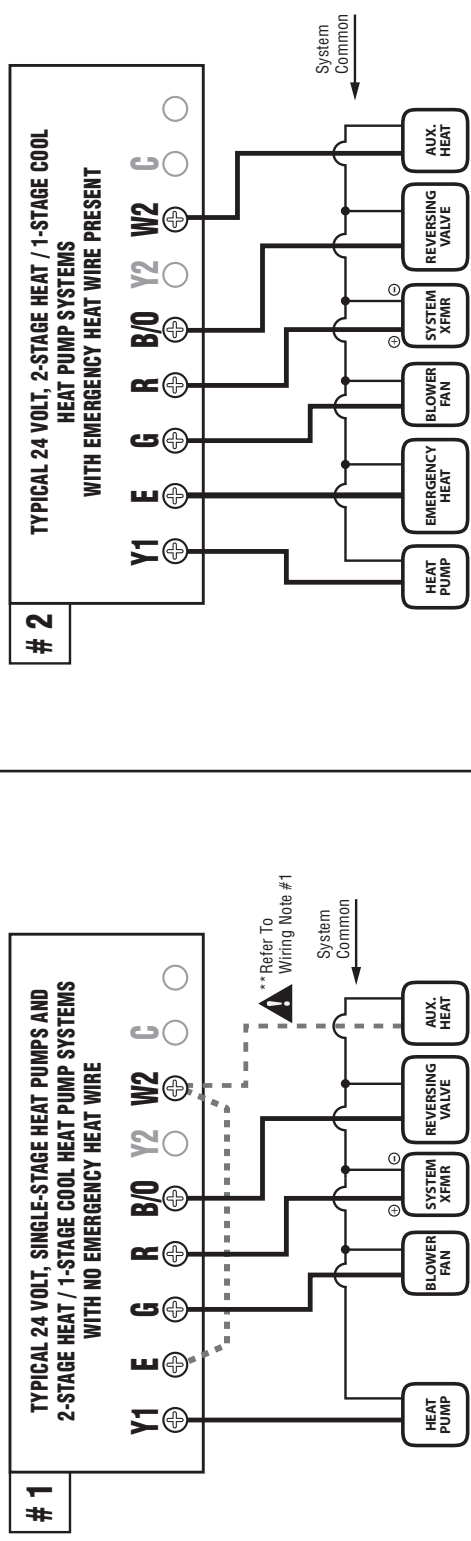

**(PSDH021Ba) FRENCH - SCHÉMAS D'IDENTIFICATION DES FILS ET DU CÂBLAGE**

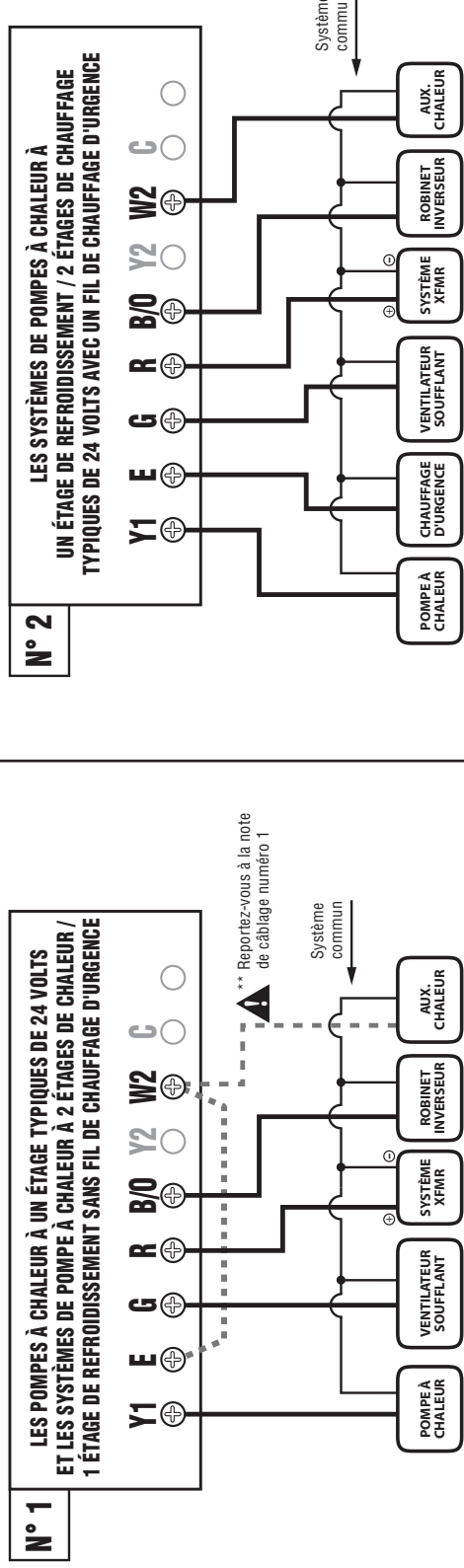

**(PSDH021Ba) - IDENTIFICACIÓN DE CABLES Y DIAGRAMAS DE CABLEADO**

